

The Heat Pulse Technique for Measuring Specific Heat and Thermal Diffusivity Applied to thin Polymeric Films

I. Engeln, I. Boro and G. Hinrichsen

Technical University of Berlin, Institute of Nonmetallic Materials, Polymer Physics, Englische Str. 20, D-1000 Berlin 12, Federal Republic of Germany

Summary

A heat pulse technique has been developed and applied to thin polymeric films in order to obtain specific heat and thermal diffusivity data. This technique allows the determination of time dependence of thermal properties, and therefore information on molecular high speed processes may be available.

Introduction

The measurement of specific heat and other thermal properties of polymeric materials are well established techniques. For example, the determination of specific heat is usually performed by applying DSC-, DTA- or adiabatic calorimeter equipments (1,2). The advantage of these measuring techniques is given by their high precision, one of their disadvantages is concerned with the relatively slow measuring speed. Molecular high speed processes can not be analyzed in a direct manner. Thermal properties of polymers are connected also with molecular movements in the half-value life interval of a tenth of a second or less. For this reason, a fast thermal technique seems to be very interesting to get insight into molecular relaxation mechanisms. Therefore, we made use of a heat pulse technique (HPT) to determine the heat capacity of polymeric films. Similar techniques have been applied to inorganic glasses in the temperature range below 2 K (3,4) and have been found to be successful in determining time-dependent thermal properties at low temperatures.

Experimental

Thin films of about 30 μm thickness consisting of poly(ethylene), poly(propylene) and poly(butene-1), respectively, were investigated. From these films rectangular stripes of 2 x 8 cm^2 were cut. Fig. 1 shows a schematic drawing of the arrangement of the generator and detector layer and the polymeric film between them. The generator layer of less than 1 μm thickness was prepared by gold sputtering using an equipment of Balzers Union Co., model no. SCD O30. The area of the heating layer was set upon 2 x 2 cm^2 .

The evaporation of the thermocouple was connected with great experimental difficulties. Because of its high thermoelectric voltage and its low melting point Cu-CuNi was chosen as thermocouple material. In order to get the desired thermocouple shape the specimen was covered by a template during evaporation.

The pretreated stripes were fixed on a special sample holder and put into a cryostat which could be evacuated to $1 \cdot 10^{-5}$ mbar pressure. The cryostat was cooled down by liquid nitrogen to 80 K and heated up during the

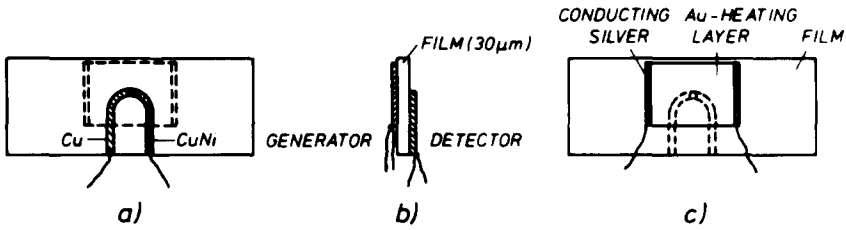

Figure 1. Schematic drawing of a polymer film for the heat pulse technique

- a) front view: thermocouple
- b) lateral view
- c) back view: generator layer

measurements up to 340 K with a heating rate of $2 \text{ K} \cdot \text{min}^{-1}$.

The experimental arrangement is shown in Fig. 2. An electrical rectangular pulse of less than 0,5 msec duration was sent to the generator layer by means of the pulse generator (PG) and amplifier. This pulse passes through the gold layer and raises the temperature of the film which is fixed in a quasi-adiabatic manner. The temperature rise $\Delta T(t)$ was detected on the opposite film surface in the form of thermoelectric power U_t which was amplified and stored by a transient-recorder (TR) as a function of time. The time slope of the temperature rise could be observed by the oscilloscope (OS) and - if desired - transferred to a HP 85 computer for further analysis.

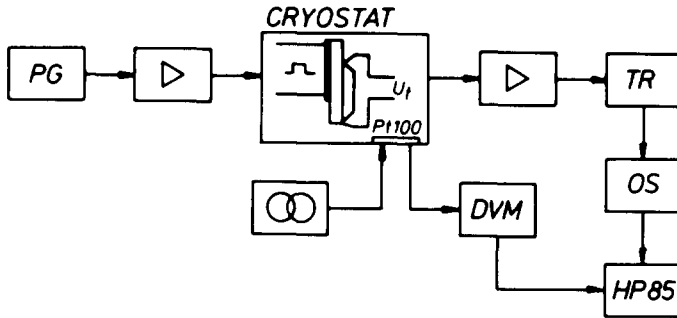

Figure 2. Block diagram of the HPT experimental arrangement

Evaluation

For calculating the specific heat $C_p(t, T)$ a reference point method was used, allowing all values of a series of measurements to be computed in relation to a chosen reference value $C_p^{\text{ref}}(t, T^{\text{ref}})$. The time-dependent specific heat at a temperature T is given by

$$C_p(t, T) = \frac{\Delta Q}{m \cdot \Delta T(t)} \quad (1)$$

where m is the effective sample-mass and ΔQ is the energy generated into

the heating resistance R_H by a pulse with voltage U and width Δt :

$$\Delta Q = \frac{U^2}{R_H} \cdot \Delta t \quad (2)$$

Finally, specific heat values can be calculated according to the reference method

$$C_p(t, T) = C_p^{\text{ref}}(t, T^{\text{ref}}) \frac{\Delta Q \cdot \Delta T^{\text{ref}}(t)}{\Delta Q^{\text{ref}} \cdot \Delta T(t)} \quad (3)$$

The advantage of this reference procedure results from the renunciation of the more inexact value of the effective specimen mass.

In addition, the thermal diffusivity a can be calculated from the temperature rise $\Delta T(t)$ according to the formula given by Erdmann (5),

$$a = 1,38 d^2 / (\pi^2 \cdot t_{0,5}) \quad (4)$$

where d is the thickness of the sample and $t_{0,5}$ is the half-crest-value time of the maximum temperature rise.

Results and discussion

The specific heat is connected with the motion of chain segments. Depending on the type and strength of the intra- and intermolecular interaction forces and sterical hindrances, various types of motions are existing requiring different half-crest-value times. The relaxation time spectrum of such movements spreads over a very large interval from 10^{-10} to 10^{10} sec. By knowing the relaxation time of a molecular process informations can be obtained about the mobility and size of the moving element.

The relaxation time of a process depends also on the absolute temperature. Below and above the glass temperature great differences in the relaxation time spectrum of an amorphous or semicrystalline material exist. The existence of time-dependent effects should result in time-dependent specific heats. According to the experimental set-up described above, the following time-dependent temperature increase ΔT -behaviour can be expected on one side of the polymer film, if a short heat pulse is generated on the opposite side: After rising to a maximum value the temperature signal

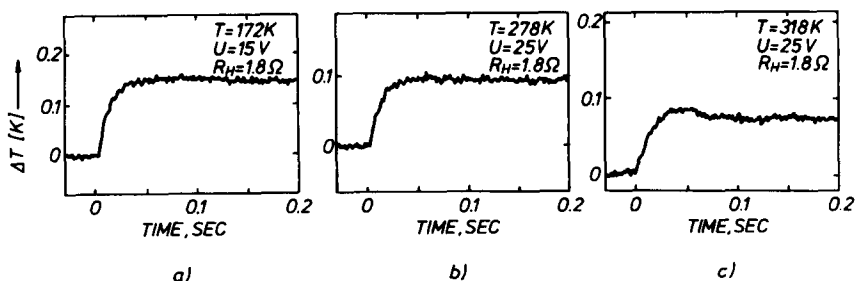

Figure 3. Measured temperature increase ΔT of a poly(butene-1) film as a function of time
a) 172 K; b) 278 K; c) 318 K

$\Delta T(t)$ falls to a lower level after a certain time interval, caused by the onset of energy consuming molecular motions with higher relaxation times (e.g. free volume formation).

Fig. 3 represents ΔT -curves for polybutene-1 obtained at different temperatures. At the highest temperature (318 K) a small ΔT -overshooting can be observed at $t \approx 40$ msec. Quasiadiabatic conditions for the experimental arrangement have been found to hold for times $t \leq 0,5$ sec and the radiation losses were estimated to be neglectable.

As the temperature increase ΔT , the effective sample mass and the generated heat quantity are rather uncertain, absolute specific heat values from HPT are only obtained using the reference method described above. The C_p -results for the investigated polypropylene-film are plotted in Fig. 4, obtained either by differential thermal analysis (DTA) or by heat pulse technique (HPT) using equ. (3). The reference temperature T_{ref} was set upon 143 K. As can be seen from Fig. 4 the C_p -values of HPT are placed below those of the DTA-curve. Although this result is in accordance with the assumption that slower energy consuming processes do not contribute to the specific heat if measurement speed is high enough, no further discussion of the data is carried out in this paper, because experimental uncertainties are still great and only little theoretical work is available. It will be mentioned that our measurements on poly(ethylene)- and poly(butene-1)-films lead to similar results.

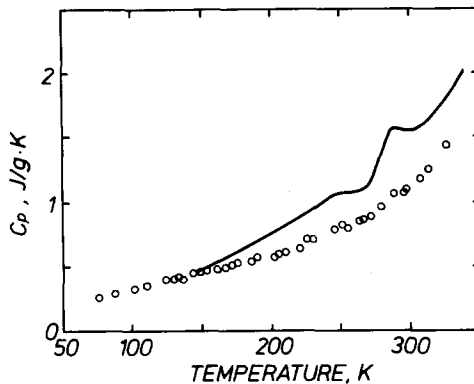

Figure 4. Specific heat of a poly(propylene)-film.
Full line: DTA measurement (heating rate $15 \text{ K} \cdot \text{min}^{-1}$)
Circles: HPT measurements

Although only preliminary investigations have been carried out up to now the results in hand and the applied heat pulse technique seem to be very interesting. Further work has to be done in order to prove the presented results and to extend the measurement interval both to lower and higher temperature.

References

1. B. Wunderlich and H. Baur, *Adv. Polymer Sci.* 7, 151 (1970)
2. J. Menczel and B. Wunderlich, *J. Polymer Sci., Polymer Lett. Ed.* 19, 261 (1981)
3. M. Meissner and K. Spitzmann, *Phys. Rev. Lett.* 46, 265 (1981)
4. M.T. Lopenen, R.C. Dynes, V. Narayanamurti, and J.P. Garino, *Phys. Rev. B* 25, 1161 (1982)
5. J.C. Erdmann, *Waermeleitung in Kristallen*, Springer-Verlag, Berlin 1962